

## 5. Operating Cylinder

### A: REMOVAL

1) Remove the intercooler. <Ref. to IN(STI)-13, REMOVAL, Intercooler.> <Ref. to IN(w/o STI)-38, REMOVAL, Intercooler.>

2) Disconnect the clutch hose from the operating cylinder.

#### CAUTION:

- Cover the hose joint to prevent the clutch fluid from flowing out.
- Do not loosen or remove the cap bolts.
- STI model

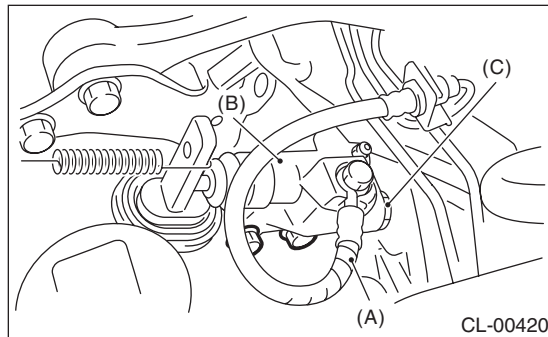

- (A) Clutch hose
- (B) Operating cylinder
- (C) Cap bolt

- Except for STI model

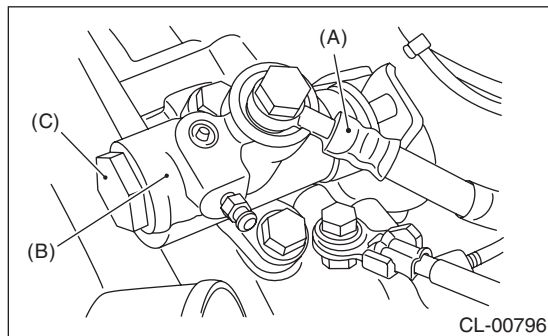

- (A) Clutch hose
- (B) Operating cylinder
- (C) Cap bolt

3) Remove the operating cylinder from the transmission.

- STI model

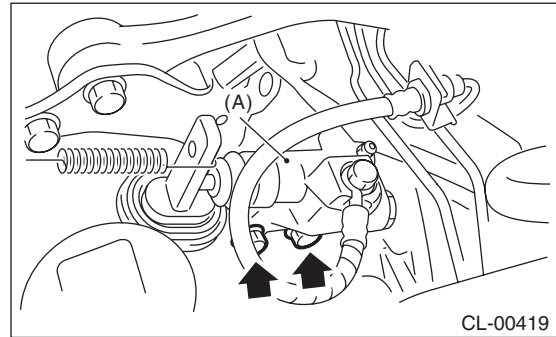

- (A) Operating cylinder

- Except for STI model

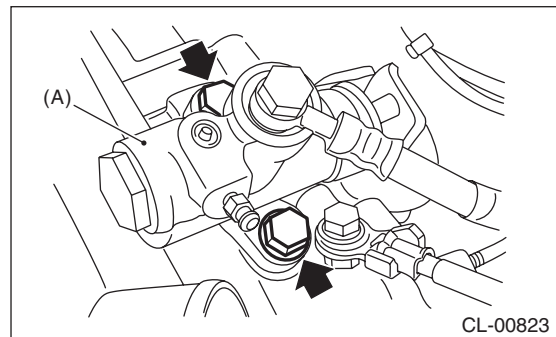

- (A) Operating cylinder

# Operating Cylinder

## CLUTCH SYSTEM

### B: INSTALLATION

1) Install in the reverse order of removal.

#### NOTE:

- Use a new washer.
- Before installing the operating cylinder, apply grease to the contact point of the release lever and operating cylinder.

#### Grease

##### **NICHIMOLY N-130 or equivalent**

- Be sure to install the clutch hose with the mark side facing upward.
- Be careful not to twist the clutch hose during installation.
- STI model

#### Tightening torque:

**T1: 18 N·m (1.8 kgf-m, 13.3 ft-lb)**

**T2: 41 N·m (4.2 kgf-m, 30.2 ft-lb)**

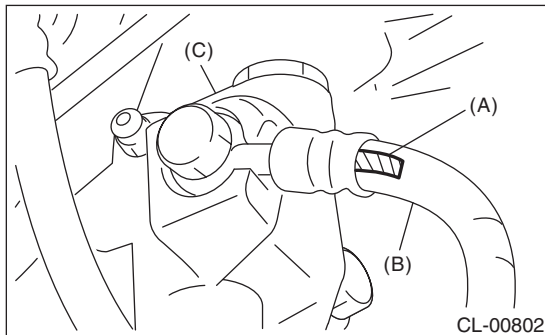
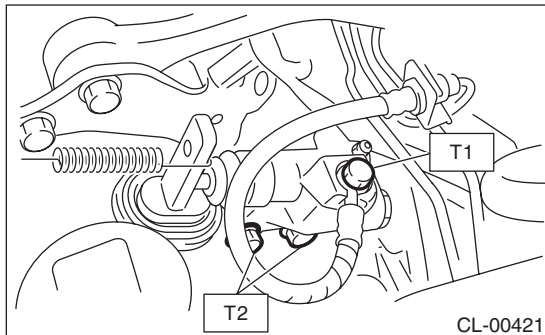

- (A) Mark
- (B) Clutch hose
- (C) Operating cylinder

- Except for STI model

#### Tightening torque:

**T1: 18 N·m (1.8 kgf-m, 13.3 ft-lb)**

**T2: 37 N·m (3.8 kgf-m, 27.3 ft-lb)**

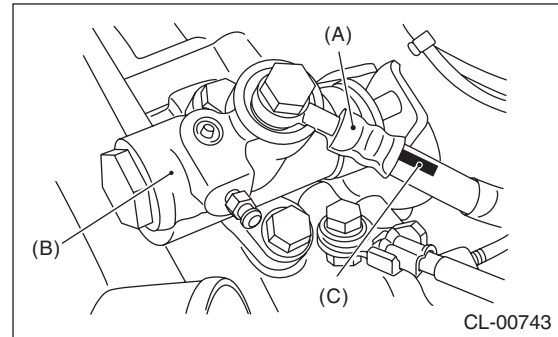
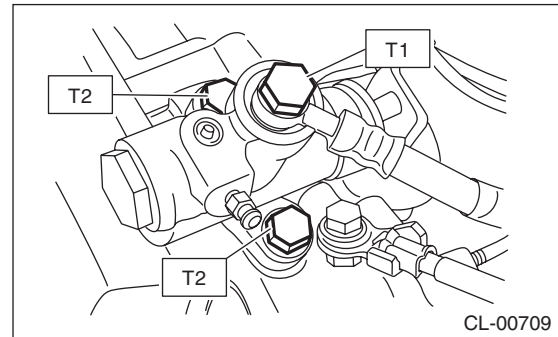

- (A) Clutch hose
- (B) Operating cylinder
- (C) Mark

2) After bleeding air from the operating cylinder, ensure that the clutch operates properly.  
<Ref. to CL-29, Clutch Fluid Air Bleeding.>

## C: DISASSEMBLY

### CAUTION:

**Do not disassemble the STI model.**

1) Remove the boot and push rod.

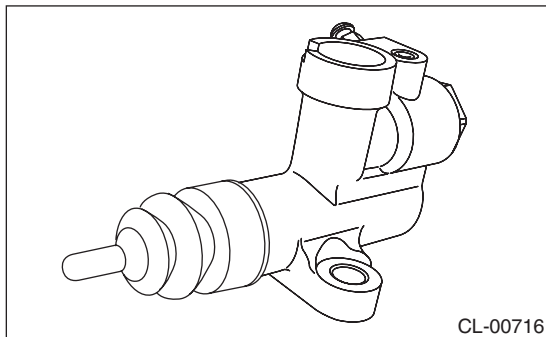

2) Apply compressed air through clutch hose attachment hole.

### NOTE:

Face the piston hole down and place a piece of wood underneath to prevent the piston from popping out.

3) Separate the piston and piston spring.

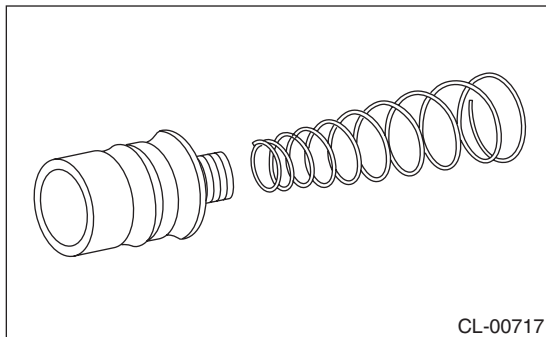

## D: ASSEMBLY

### NOTE:

During assembly, apply hydraulic oil to all parts.

### **Recommended clutch fluid:**

**New FMVSS No. 116 DOT3 or DOT4**

- 1) Install the piston spring onto the piston.
- 2) Insert piston into the operating cylinder.
- 3) Install push rod to the boot.
- 4) Install boot and push rod to the operating cylinder.

## E: INSPECTION

- 1) Check that the operating cylinder is not damaged. If operating cylinder is damaged, replace it.
- 2) Check the operating cylinder for fluid leakage or damage on the boot. Replace the operating cylinder if leaks or damages are noted.